

SNIBO
Innovation in Motion



CURVED RAIL

SAIBO is one of world recognized manufacturers of precision power transmission components. SAIBO group has two divisions, linear motion division and bearing division. Linear Product Division mainly produces curved rail and conveyor, telescopic rail and fork, linear guide, linear module, belt conveyor etc. Bearing Division mainly produces Thin-section bearing, High-speed angular contact ball bearing, linear bearing etc.

SAIBO products are widely used in 3C, factory automation, precision machine, green energy, rail transportation, medical and pharmacy etc. industries. SAIBO end users are located in more than 50 countries and regions around the world.

SAIBO has over 33,000 square meters producing facilities totally and 350 employees. SAIBO continues to develop innovative automation components and modulars to meet customers sustainable solutions.

SAIBO means aim for greatness, focus on details. We seek to work with you and promise the following:

- The right product from your application
- A quality product you can trust
- Engineering assistance that is proven and world renown

Straight Rail

Made of Germany high quality bearing steel
 Deep hardened in working surfaces for high wear resistance
 Ground Double 70° V working edges together to ensure parallelism
 Soft rail body for customization machining process
 Provide 3 standard sizes for customer's selection
 Two precision rails G1 and G3 is optional, ground and un-ground
 Precision G3 rail length could be up to 5.5 meters without connection
 Longer length (Unlimited) can be achieved by Connection

Ring Rail

Made of high quality bearing steel
 Deep hardened in working surfaces for high wear resistance
 Ground Double 70° V working edge ensure parallelism
 All surfaces are ground for precision
 Provide wide range of standard sizes
 Customized assembly holes are available

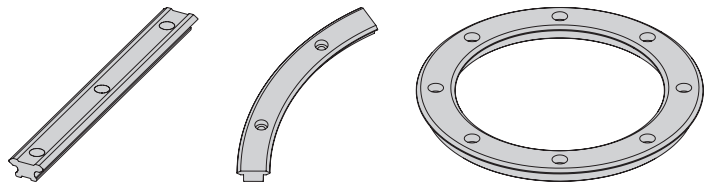

Precision

SAIBO provides two precision grades. G1 ground and G3 unground. Here we must emphasize that G3 grade's motion is also very smooth and stable. It is fit for smooth running without very high precision and low cost request. But when linear rail connect ring rail, it must be G1 grade.

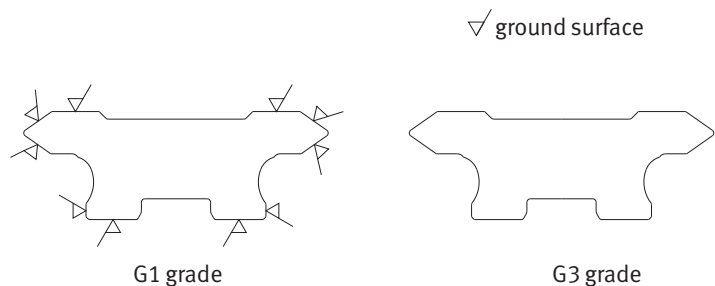

Roller Made of high quality bearing steel
 Whole body hardened for high wear resistance
 Supply Twin and Double row bearings
 (See below figure)
 Concentric / Eccentric bolt supplied

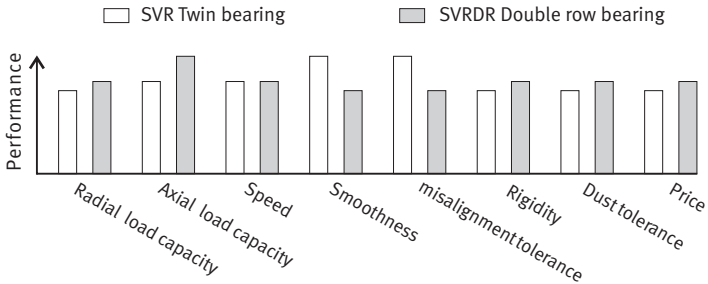
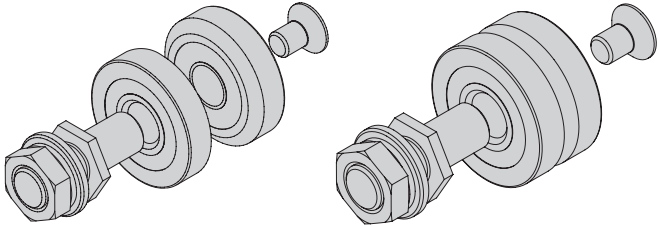

Floating Bearing Outer ring could float in axial direction to compensate installation parallelism
 Made of high quality bearing steel
 Whole body hardened for high wear resistance
 Concentric / Eccentric bolt supplied

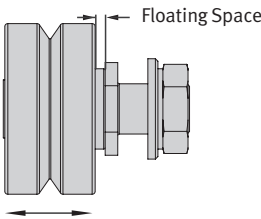

Roller Type Selection

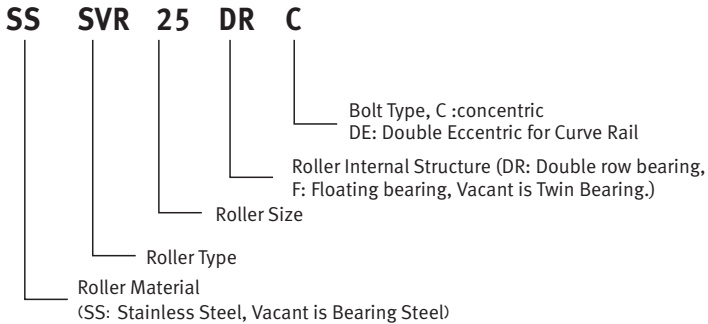

Roller Type Selection Please refer to page P11-P12.

Cap Seal

Protect bearing against dust

Protect operator for safety

Lubricated felt wiper contact rail's working surface to increase load capacity and life

Standard and interchangeable

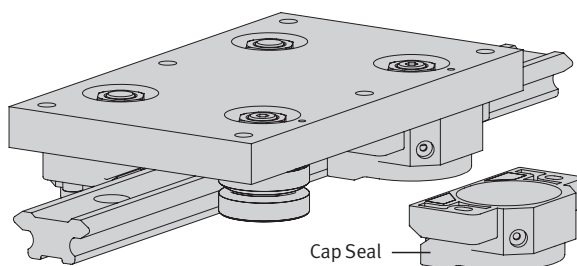

Lubricate Wiper

Lubricated felt wiper contact rail's working surface to increase load capacity and life

Lubricated felt wiper is pushed lightly by a small spring to ensure low friction with the rail's working surface

Easy to fill lubricate oil from its fill hole

Standard and interchangeable

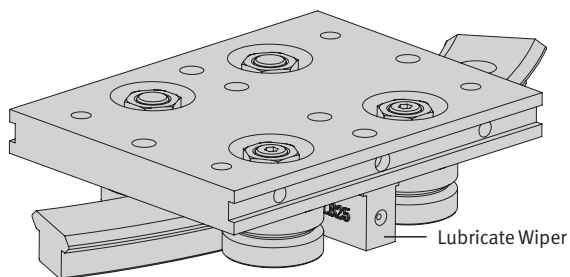

Lubricate System

Lubricated felt wiper contact rail's working surface to increase load capacity and life

Lubricated felt wiper is pushed lightly by a small spring to ensure low friction with the rail's working surface

Oil charging holes supplied for the Track Motion System

Automatic lubricate bleed could connect to the rail's oil charging holes very easily.

Standard and interchangeable

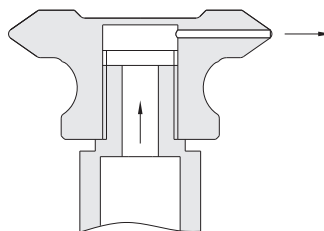
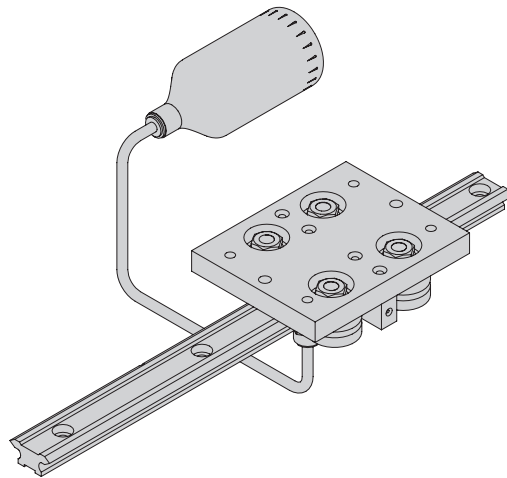

Oval Circular Rail

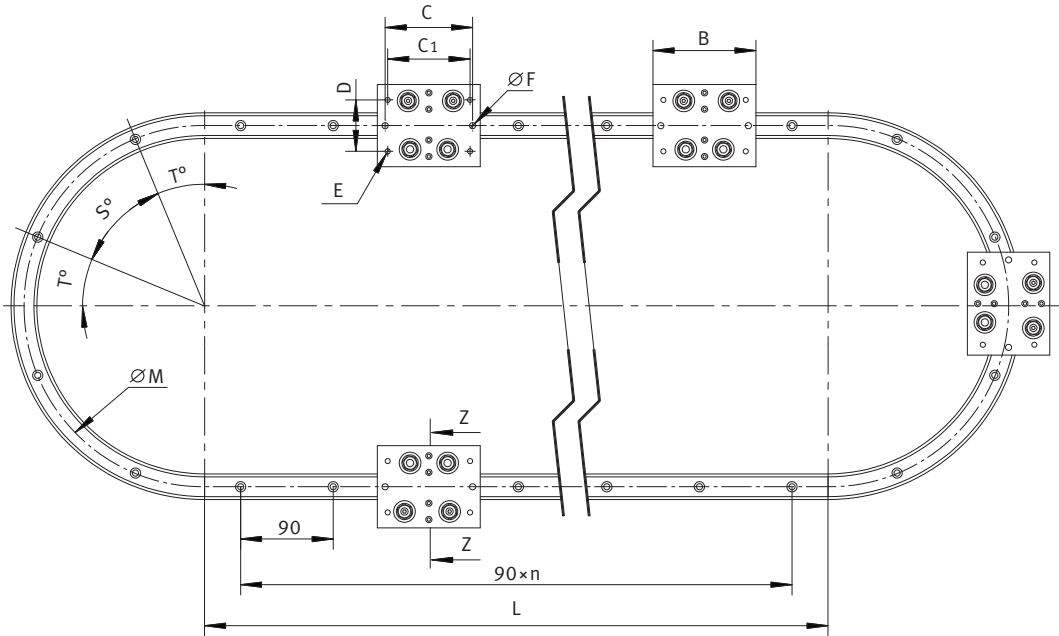

Assembly code	Components			A	B
	Straight Rail	Ring Rail	Carriage		
LGV25XL-CR25 159 R180	LGV25XL	CR25 159 R180	SRC25 159	80	95
LGV25XL-CR25 255 R180		CR25 255 R180	SRC25 255		100
LGV25XL-CR25 351 R180		CR25 351 R180	SRC25 351		105
LGV44XL-CR44 468 R180	LGV44XL	CR44 468 R180	SRC44 468	116	145
LGV44XL-CR44 612 R180		CR44 612 R180	SRC44 612		150
LGV76XL-CR76 799 R180	LGV76XL	CR76 799 R180	SRC76 799	185	190
LGV76XL-CR76 1033 R180		CR76 1033 R180	SRC76 1033		210
LGV76XL-CR76 1267 R180		CR76 1267 R180	SRC76 1267		250
LGV76XL-CR76 1501 R180		CR76 1501 R180	SRC76 1501		270

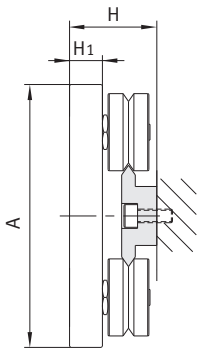

Z-Z

Type Code

LGV 25 x 2000-CR25 159 R180

Segment angular: 180°

Ring railway diameter

Ring railway size

Railway length

Railway size

Linear railway

Dimension									
C	C ₁	D	E	ØF	H	H ₁	M	S°	T°
80	85	50	4xM6	2-Ø6	30.5	11.5	159	45	22.5
85	80		4xM6	2-Ø6			255	45	22.5
90	85		4xM6	2-Ø6			351	30	15
125	120	75	4xM8	2-Ø8	38.5	14.5	468	30	15
130	125		4xM8	2-Ø8			612	22.5	11.25
165	160	100	4xM10	2-Ø10	58.5	20	799	22.5	11.25
185	180		4xM10	2-Ø10			1033	18	9
225	205		4xM10	2-Ø10			1267	18	9
245	225		4xM10	2-Ø10			1501	18	9

Ring Rail

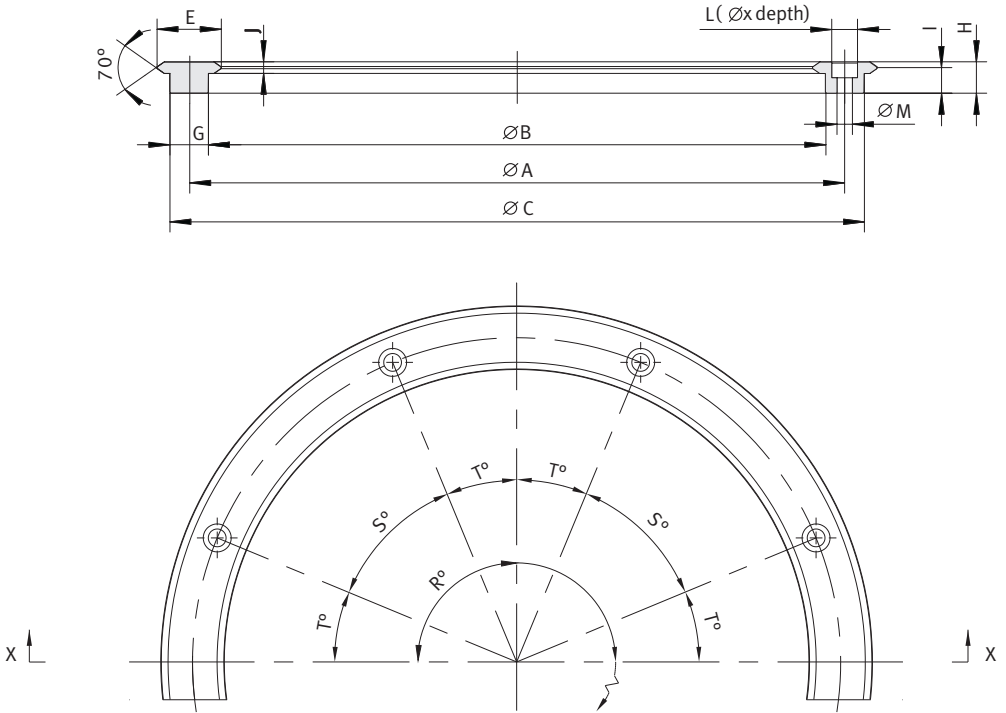

Type	Applicable Bearing	A	B	C	E	G	H
CR25 159	SVR-25	159	144	174	25	15	12.25
CR25 255	SVR-25	255	240	270	25	15	12.25
CR25 351	SVR-25	351	336	366	25	15	12.25
CR44 468	SVR-34	468	442	494	44	26	15.5
CR44 612	SVR-34	612	586	638	44	26	15.5
CR76 799	SVR-54	799	749	849	76	50	24
CR76 1033	SVR-54	1033	983	1083	76	50	24
CR76 1267	SVR-54	1267	1217	1317	76	50	24
CR76 1501	SVR-54	1501	1451	1551	76	50	24

Type Code

CR25 351 R180

Segment angular 90°、180°、full 360° Ring

Ring rail size

I	J	L (Ø×depth)	Ø M	Hole Number (R=360°)	Hole Position ±0.2		Weight (kg) (R=360°)
					S°	T°	
10	4.5	9.5x7	6	8	45	22.5	0.77
10	4.5	9.5x7	6	8	45	22.5	1.2
10	4.5	9.5x7	6	12	30	15	1.65
12.5	6	11x8	7	12	30	15	5.1
12.5	6	11x8	7	16	22.5	11.25	6.7
19.5	9	20x13	14	16	22.5	11.25	25
19.5	9	20x13	14	20	18	9	32
19.5	9	20x13	14	20	18	9	41
19.5	9	20x13	14	20	18	9	48.7

Straight Rail

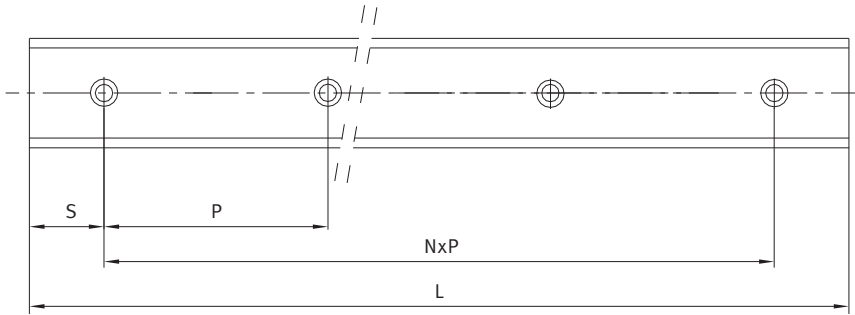

Type	A		B		C	
	G1	G3	G1	G3	G1	G3
LGV25XL	25	25.12	12.25	12.85	15	15.5
LGV44XL	44	44.12	15.5	16.1	26	26.5
LGV76XL	76	76.12	24	24.6	50	50.5

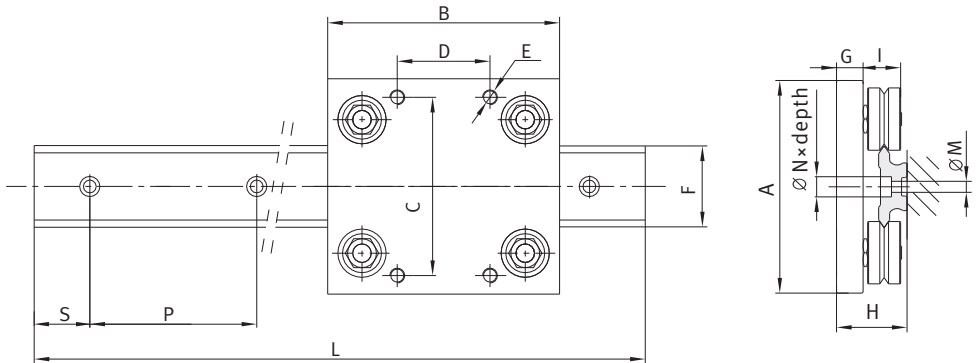

SLCA

Rail	Carriage	Roller	Dimension					
			A	B	C	D	E	F
LGV25XL	SLC25A	SVR-25C	80	80	65	24	4xM6	25
	SLC25B	SVR-25DE		135		60	6xM6	
	SLC25C			180		82	6xM6	
LGV44XL	SLC44A	SVR-34C	116	125	96	50	4xM8	44
	SLC44B	SVR-34DE		180		80	6xM8	
	SLC44C			225		103	6xM8	
LGV76XL	SLC76A	SVR-54C	185	200	160	90	4xM10	76
	SLC76B	SVR-54DE		300		135	6xM10	
	SLC76C			400		185	6xM10	

Type Code

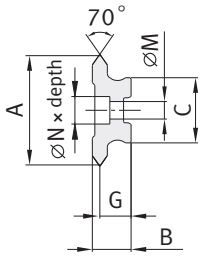

G3 LGV 25 x 1000

Railway length

Railway size

Linear railway

Precision grade G1 or G3

G		M	N x depth	P	S	Lmax	
G1	G3					G1	G3
10	10.25	6	9.5x7	90	$10 \leq S < 55$	4000	5500
12.5	12.75	7	11x8	90	$10 \leq S < 55$	4000	5500
19.5	19.75	14	20x13	90	$15 \leq S < 60$	4000	5500

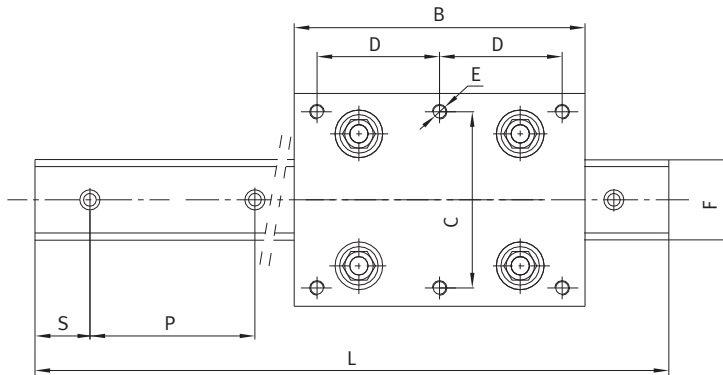

SLC B/C

G	H		I	M	N x depth	P	S	Lmax	
	G1	G3						G1	G3
11.5	30.5	30.75	16.5	6	9.5x7	90	$10 \leq S < 55$	4000	5500
14.5	38.5	38.75	21	7	11x8	90	$10 \leq S < 55$	4000	5500
20	58.5	58.75	33.5	14	20x13	90	$15 \leq S < 60$	4000	5500

Rollers

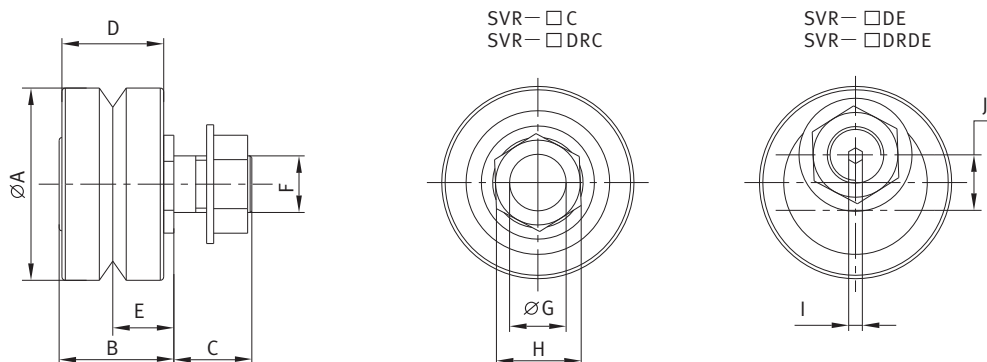

Type	Roller Category	Outer Diameter A	Eccentrical Distance J	Bearing Load Capacities(N)			
				Radial		Axial	
				Co	C	Co	C
SVR-25C	Twin bearing	25	-	1320	3320	330	800
SVR-25DE			2				
SVR-25DRC	Double row bearing		-	2535	7710	840	1650
SVR-25DRDE			2				
SVR-25FC	Floating bearing		-	6150	4980	-	-
SVR-25FDE			2				
SVR-34C	Twin bearing	34	-	2630	5980	560	1280
SVR-34DE			2.5				
SVR-34DRC	Double row bearing		-	5260	9690	1380	2540
SVR-34DRDE			2.5				
SVR-34FC	Floating bearing		-	12600	11000	-	-
SVR-34FDE			2.5				
SVR-54C	Twin bearing	54	-	6700	13700	1180	2350
SVR-54DE			5.5				
SVR-54DRC	Double row bearing		-	13400	22200	2800	4650
SVR-54DRDE			5.5				
SVR-54FC	Floating bearing		-	29000	21300	-	-
SVR-54FDE			5.5				

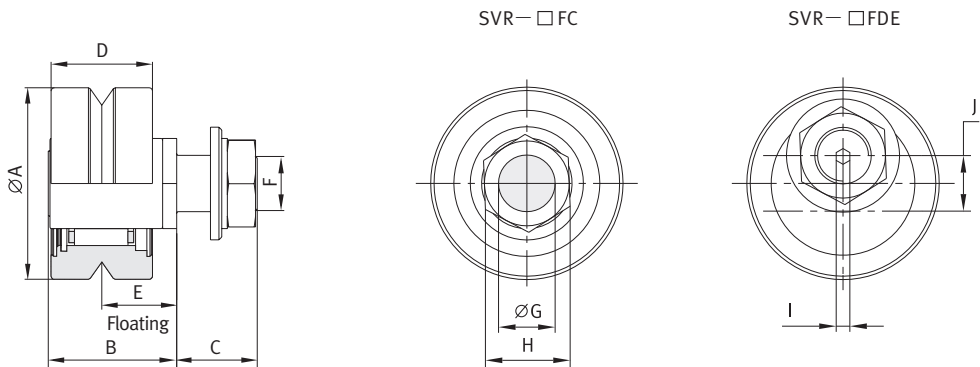

Dimension								
B	C	D	E		F	G	H	I
16.5	11.3	14	9		M8 x 1	8	13	3
18.1	11.3		Max 10.5	Min 9				
21	14.3	18	11.5		M10 x 1.25	10	15	4
23.2	14.3		Max 13.5	Min 11.5				
33.5	19.8	28	19		M14 x 1.5	14	27	6
37.2	19.8		Max 21.6	Min 19				

Notes: SAIBO currently applied twin bearings by default.

Assembly manual

1. Match rollers to carriage plate

Please mount the concentric bearing to one side of carriage plate, and eccentric bearing to the other side following the direction of railway. In case of circle motion carriage, the concentric bearing should be mounted to the side where mounting-hole distance is shorter. Please refer to below picture.

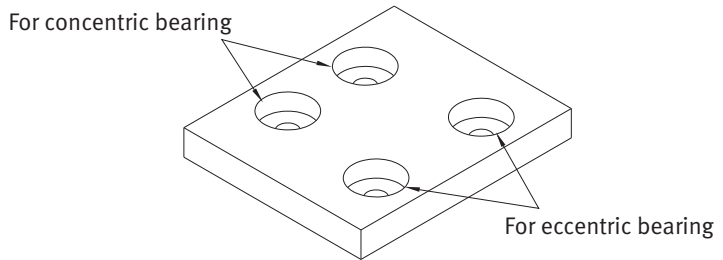

Circle motion carriage plate

2. Mounting to railway

Carriage assembly should be mounted from the end of railway. Please do not put any overstress when mounting.

3. Adjust the clearance between bearing and railway

- Tighten concentric bearings first.
- Then rotate eccentric bearing via rotate hexagonal key at the end of stud to adjust the clearance between railway and bearing.
- Adjust the clearance to zero.
- Slide the carriage by hand and adjust to the extent where there causes a slight slipping resistance.

Correct condition is where moving power becomes the recommended value as below table by putting load by push-pull gauge to the running direction of carriage.

Recommended pre-load by push-pull gauge

V track bearing size	Pre-load(N)
25	4
44	8
76	12

-Keep eccentric bearing's position and tighten the nut.

Important note

Appropriate pre-load provide the system rigidity. However, over preload will decrease system's life rapidly. Please be careful.

Load / Life calculation

Due to the hardness of the railway and fatigue analysis of railway and roller, the railway's life does not determine the system life. It is determined by roller's life. Load capacity of the motion guide system varies mainly by the size of bearing and railway, lubricated or not, and the load magnitude and direction. Other factors include speed and acceleration and environment etc. To calculate system life, loading factor LF should be calculated firstly. Here we provide two methods to calculate the loading factor.

Standard 4 bearings carriage calculation

If the system use SAIBO standard 4 bearings carriage, then calculation can use below formula.

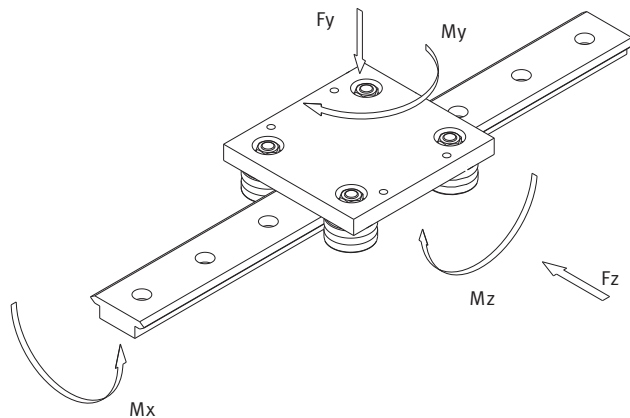

$$LF = \frac{F_y}{F_{y\max}} + \frac{F_z}{F_{z\max}} + \frac{M_x}{M_{x\max}} + \frac{M_y}{M_{y\max}} + \frac{M_z}{M_{z\max}}$$

F_y - Actual load in Y direction. (N)

F_z - Actual load in Z direction. (N)

M_x - Actual moment in X direction. (N·m)

M_y - Actual moment in Y direction. (N·m)

M_z - Actual moment in Z direction. (N·m)

Below parameters can be taken from the table of Load capacity.

F_{y max} - Max load capacity in Y direction. (N)

F_{z max} - Max load capacity in Z direction. (N)

M_{x max} - Max moment capacity in X direction. (N·m)

M_{y max} - Max moment capacity in Y direction. (N·m)

M_{z max} - Max moment capacity in Z direction. (N·m)

Straight rail carriage's load capacity

Carriage Type	Dry system Double Row Bearings and Twin Bearings					Lubricated system/Twin Bearings					Lubricated system/Double Row Bearings				
	Fy	Fz	Mx	My	Mz	Fy	Fz	Mx	My	Mz	Fy	Fz	Mx	My	Mz
	N	N	Nm	Nm	Nm	N	N	Nm	Nm	Nm	N	N	Nm	Nm	Nm
SLC25	410	410	4.6	200xD	200xD	1300	1225	14	600xD	640xD	1610	3020	18.2	1500xD	800xD
SLC44	790	790	16	400xD	400xD	3250	2830	65	1400xD	1600xD	3620	6050	74	3000xD	1800xD
SLC76	1850	1850	65	900xD	900xD	7250	6380	255	3200xD	3600xD	10050	10050	365	5000xD	5000xD

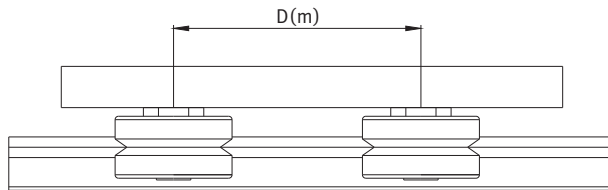

Ring rail carriage's load capacity

Carriage Type	Dry system Double Row Bearings and Twin Bearings					Lubricated system/Twin Bearings					Lubricated system/Double Row Bearings				
	Fy	Fz	Mx	My	Mz	Fy	Fz	Mx	My	Mz	Fy	Fz	Mx	My	Mz
	N	N	Nm	Nm	Nm	N	N	Nm	Nm	Nm	N	N	Nm	Nm	Nm
SRC25 159	410	410	4.6	8.7	8.7	1300	1225	14	25.5	27.5	1610	3020	18.2	65	33.5
SRC25 255	410	410	4.6	8.2	8.2	1300	1225	14	23.5	25.5	1610	3020	18.2	60	31.5
SRC25 351	410	410	4.6	8.7	8.7	1300	1225	14	24.5	27.5	1610	3020	18.2	64	33.5
SRC44 468	790	790	16	28.2	28.2	3250	2830	65	97	112	3620	6050	74	215	120
SRC44 612	790	790	16	28	28	3250	2830	65	100	110	3620	6050	74	225	130
SRC76 799	1850	1850	65	87	87	7250	6380	255	305	345	10050	10050	365	480	480
SRC76 1033	1850	1850	65	105	105	7250	6380	255	365	415	10050	10050	365	580	580
SRC76 1267	1850	1850	65	122	122	7250	6380	255	425	480	10050	10050	365	680	680
SRC76 1501	1850	1850	65	138	138	7250	6380	255	490	550	10050	10050	365	780	780

Roller load factor

If the system does not use SAIBO standard 4 roller carriage, It is necessary to calculate each roller's loading factor. Biggest loaded roller's load determines the system's life.

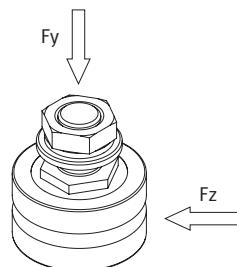

$$LF = \frac{F_y}{F_{y\max}} + \frac{F_z}{F_{z\max}}$$

LF - Loading factor

LF should be less than 1.0 for any combination of load

F_y - Actual axial capacity. (N)

F_z - Actual radial capacity. (N)

Below parameters can be taken from below table.

F_{y max} - Max axial load. (N)

F_{z max} - Max radial load. (N)

Roller's load capacity Please refer to page 11.

Life calculation After getting Loading Factor LF, the life in km can be calculated by selecting one of below two formulas. The basic life can be taken from table below.

Dry system

$$\text{Life(km)} = \frac{\text{Basic_life}}{(0.03+0.97LF*f)^2}$$

Lubricated system

$$\text{Life(km)} = \frac{\text{Basic_life}}{(0.03+0.97LF*f)^3}$$

Basic life

Bearing type	Dry system	Lubricated system
SVR-25	100	150
SVR-34	100	150
SVR-54	150	250

f - Reduction coefficient of the application and environment.

None vibration or shock, Low speed (<1m/s), Low frequency shift direction, clean environment.	1-1.5
Light vibration or shock, medium speed (1-2.5m/s) medium frequency shift direction, some dirtiness	1.5-2
Heavy vibration or shock, high speed (>2.5m/s) high frequency shift direction, heavy dirty	2-3.5

Calculation example

A machine use SB-LGV25 spacer railway and standard carriage. The carriage and work-piece total weight 8 kg. When the carriage moving, there is an external load of 50 N exerted as below drawing. Working environment is clean. There is none vibration or shock.

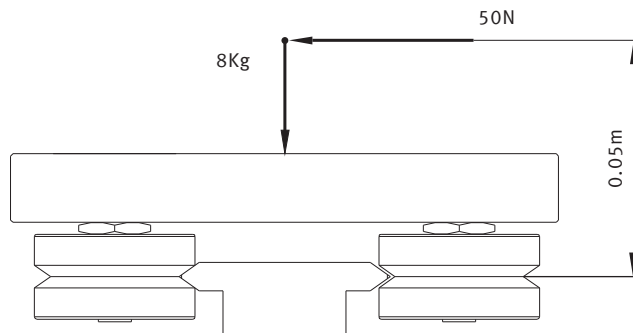

**The load factor LF is
calculated use formula**

$$LF = \frac{F_y}{F_{y\max}} + \frac{F_z}{F_{z\max}} + \frac{M_x}{M_{x\max}} + \frac{M_y}{M_{y\max}} + \frac{M_z}{M_{z\max}}$$

$$F_y = 8\text{kg} \times 9.8 \text{ (gravity)} = 78.40 \text{ N}$$

$$F_z = 50 \text{ N}$$

$$M_x = 50 \times 0.05 = 2.5 \text{ N}\cdot\text{m}$$

$$M_y = 0$$

$$M_z = 0$$

Take parameters $F_y \max$, $F_z \max$, $M_x \max$, $M_y \max$, $M_z \max$ from table and then fill in the formula

$$LF = \frac{78.4}{1280} + \frac{50}{1200} + \frac{2.5}{14} + \frac{0}{M_{y\max}} + \frac{0}{M_{z\max}} = 0.2816$$

Then life (km) calculation can use formula as below:

Dry system

$$\text{Life(km)} = \frac{\text{Basic_life}}{(0.03+0.97LF*f)^2}$$

Basic life is 100km.

According to the description of working condition, take $f=1.3$.

$$\text{Life(km)} = \frac{100}{(0.03+0.97*0.2816*1.3)^2} = 674\text{km}$$

Lubricated system

Basic life is 150 km, take $f=1.1$

$$\text{Life(km)} = \frac{\text{Basic_life}}{(0.03+0.97LF*f)^3}$$

$$\text{Life(km)} = \frac{150}{(0.03+0.97*0.2816*1.1)^3} = 4155\text{km}$$

From this example, it shows clearly that lubrication is so important for the life. Please pay attention to install the lubrication system for your system.

Oval Circular Conveyor

SAIBO curve and ring rails' main application is oval circular conveyor module which is driven by timing belt. SAIBO has standardized these conveyors to a series of modules. The module has following advantages: simple structure, Stable and reliable performance, high speed, high positioning accuracy etc.

Main components are linear and ring rails, carriage with rollers, teeth belt and pulleys, connection parts between teeth belt and carriages, position device etc.

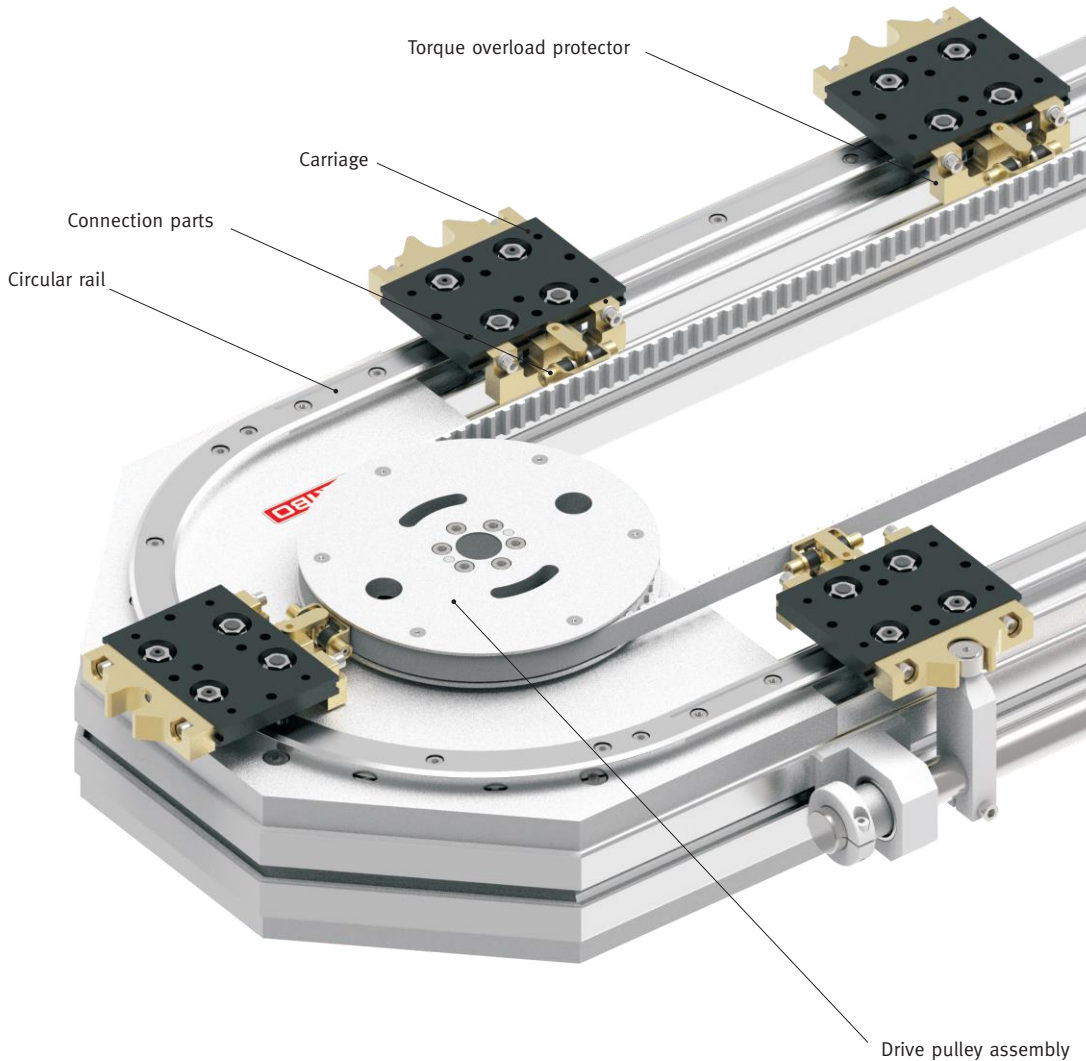

Indexing Conveyor

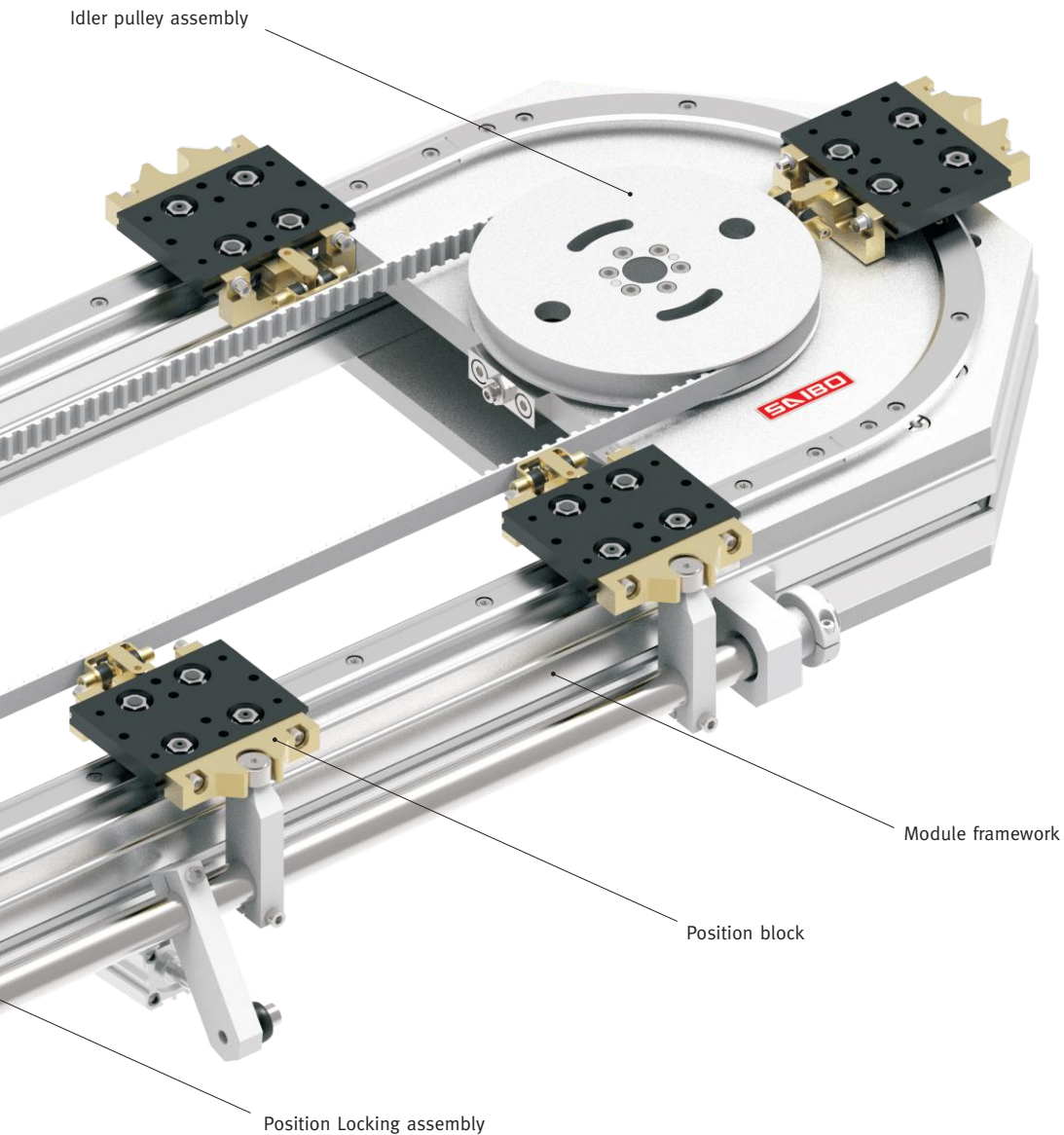

- All parts designed standard
- Supply individual components
- Stainless steel components are available

Convey Capacity

Single carriage's load capacity and running speed are two most important indicators of conveyor capacity. Normally the greater load on the carriage, the smaller speed it runs.

According to ring rail's diameter, there are four standard size circular conveyor modules. They are D255, D351, D468 and D612. Below chart shows the reference between carriage's load capacity and speed in the condition of horizontal installation.

The reference between carriage's load capacity and speed

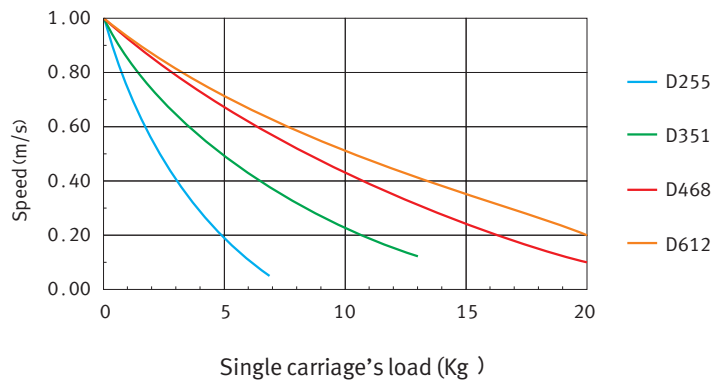

Above chart data is tested in the conditions of

1. Conveyor is installed horizontal and the rail is in well lubricated.
2. Load gravity center is located at the center of the carriage meanwhile the load does not exceed carriage's space.
3. Appropriate temperature and humidity, clean working condition.

Carriage's quantity is another one of important influence factors of convey capacity. Long rails with a big number of carriages will make single carriage's load capacity smaller at a constant driving force. Please contact us when need those special applications. We provide professional solutions.

Recommend Load

Size	Recommend Load		Max Load	
	Load for Single Carriage (Kg)	Speed (m/s)	Load for Single Carriage (Kg)	Speed (m/s)
D255	3	0.4	6	0.1
D351	5	0.5	12	0.1
D468	10	0.5	20	0.1
D612	10	0.5	20	0.2

Stability and Reliability

1. Based on the design criteria of this ring rail, one of rollers will develop a small clearance momentarily when carriage running across the joint of straight rail and ring rail. This frequent on-and-off clearance is a small shock for this conveyor. We optimize the parameter to reduce the clearance value and then reduce the shock. But it could not completely eliminate.

2. High speed, big load or big arm of the force will enlarge above shock.

Strongly Recommend

We strongly recommend size D351 and D612 modules. Because these two size rails momentarily clearances are smaller than other sizes. Furthermore our numerous applications proved these two size conveyors are most stable and reliable.

Conveyor Parameter

MOV25-D255R180-L-CA □

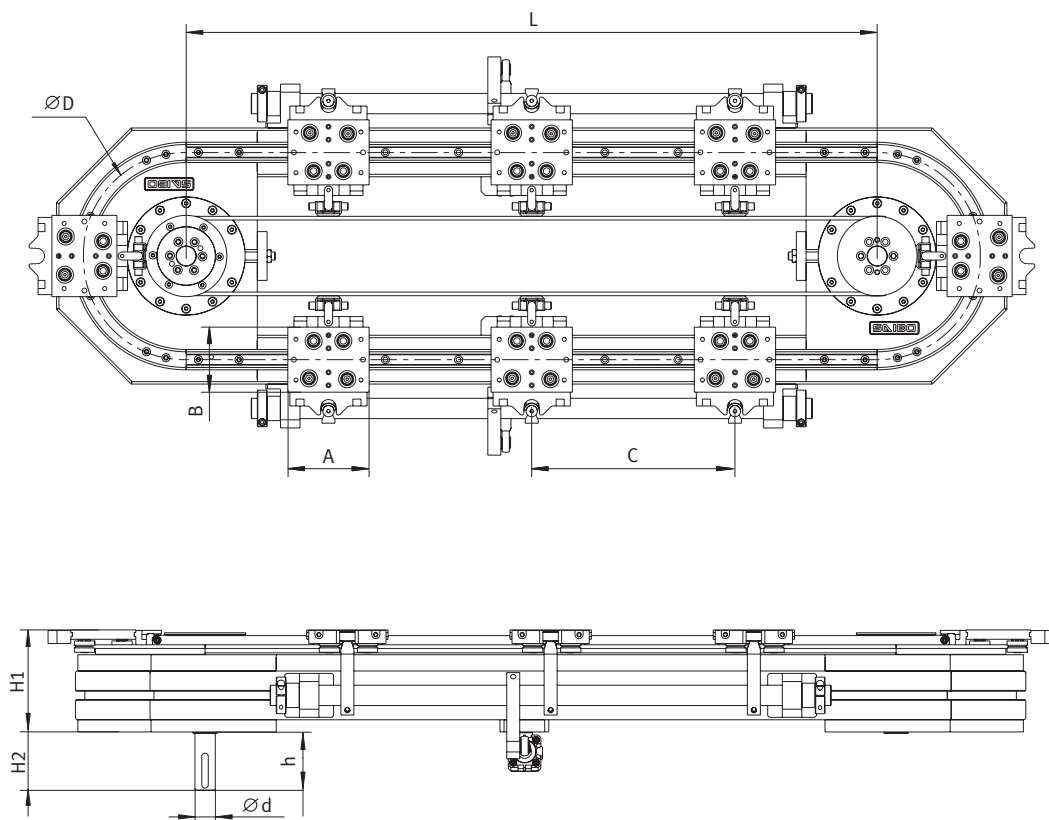

Ring Rail Diameter $\varnothing D$	A	B	H1	H2	$\varnothing d$	h
$\varnothing 255$	100	80	130.5	67	25	39.9

1. Circular Rail Type Number: LGV25XL-CR25 255 R180

Carriage Type Number: SRC25 255

2. Carriages' distance C could be customized set. We suggest $C \geq 110$ when position locking system applied.

3. Linear rail length L should be determined by carriage's number and distance.

MOV25-D351R180-L-CA □

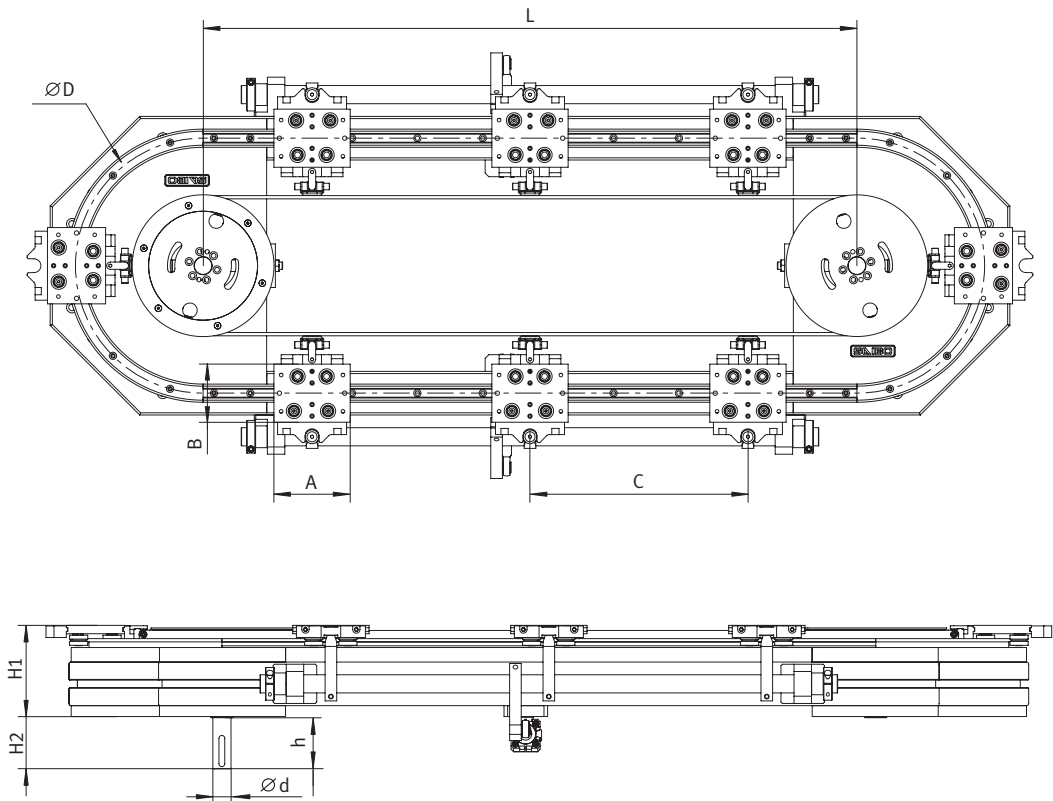

Ring Rail Diameter $\varnothing D$	A	B	H1	H2	$\varnothing d$	h
$\varnothing 351$	105	80	130.5	67	25	39.9

1. Circular Rail Type Number: LGV25XL-CR25 351 R180

Carriage Type Number: SRC25 351

2. Carriages' distance C could be customized set. We suggest $C \geq 120$ when position locking system applied.

3. Linear rail length L should be determined by carriage's number and distance.

MOV44-D468R180-L-CA □

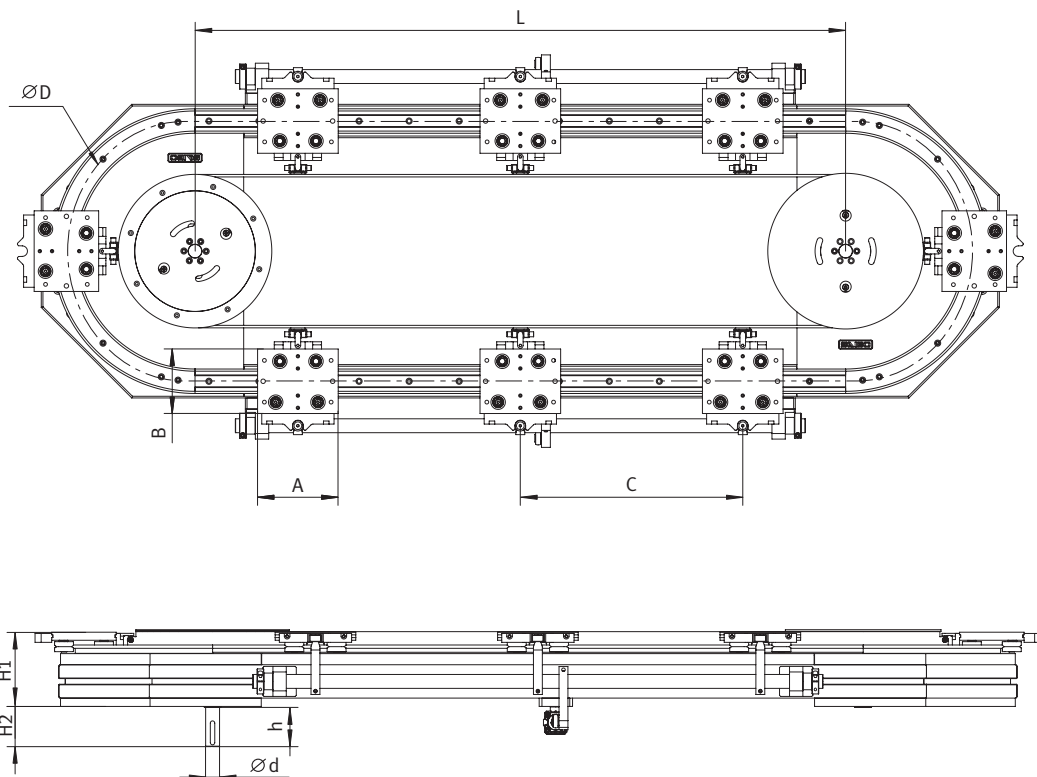

Ring Rail Diameter $\varnothing D$	A	B	H1	H2	$\varnothing d$	h
$\varnothing 468$	145	116	138.5	67	25	39.9

1. Circular Rail Type Number: LGV44XL-CR44 468 R180

Carriage Type Number: SRC44 468

2. Carriages' distance C could be customized set. We suggest $C \geq 160$ when position locking system applied.

3. Linear rail length L should be determined by carriage's number and distance.

MOV44-D612R180-L-CA □

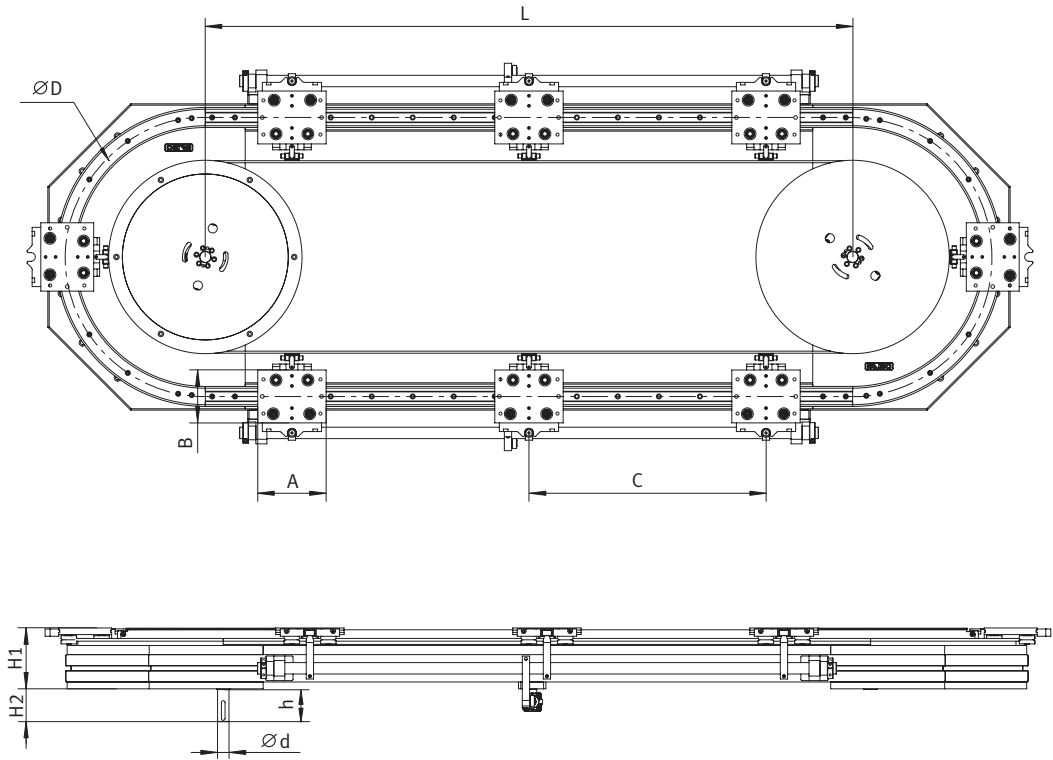

Ring Rail Diameter $\varnothing D$	A	B	H1	H2	$\varnothing d$	h
$\varnothing 612$	150	116	138.5	67	25	39.9

1. Circular Rail Type Number: LGV44XL-CR44 612 R180
Carriage Type Number: SRC44 612
2. Carriages' distance C could be customized set. We suggest $C \geq 180$ when position locking system applied.
3. Linear rail length L should be determined by carriage's number and distance.

Vertical Conveyor

According to load and torque, single or double guide rail are available. The double guide rail conveyor is suitable for applications with heavy load and high torque. This double guide rail conveyor can also be used horizontally and can bear large loads on the side. The characteristic is stable and reliable.

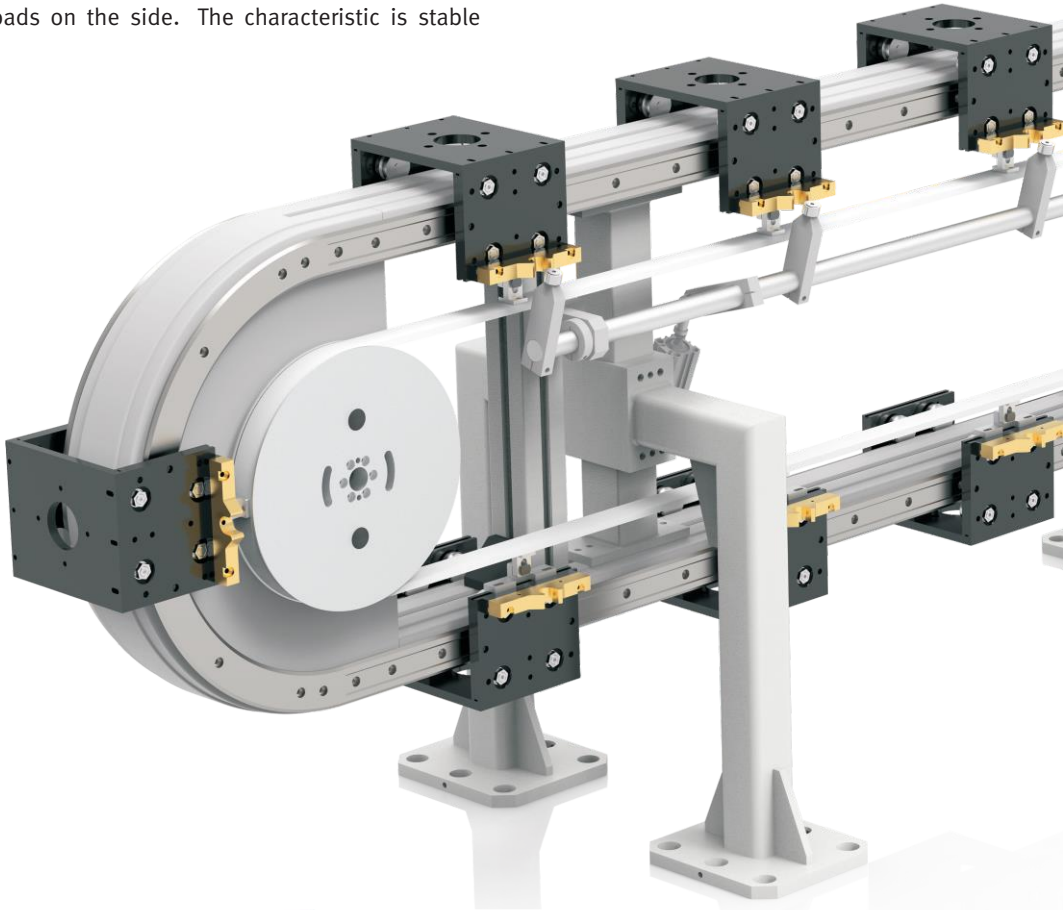

Rectangle Conveyor

This conveyor has four straight line that can be used as production stations. More actuators, robots and the other devices can be configured along with the straight line flexibly. straight line length can be extended infinitely.

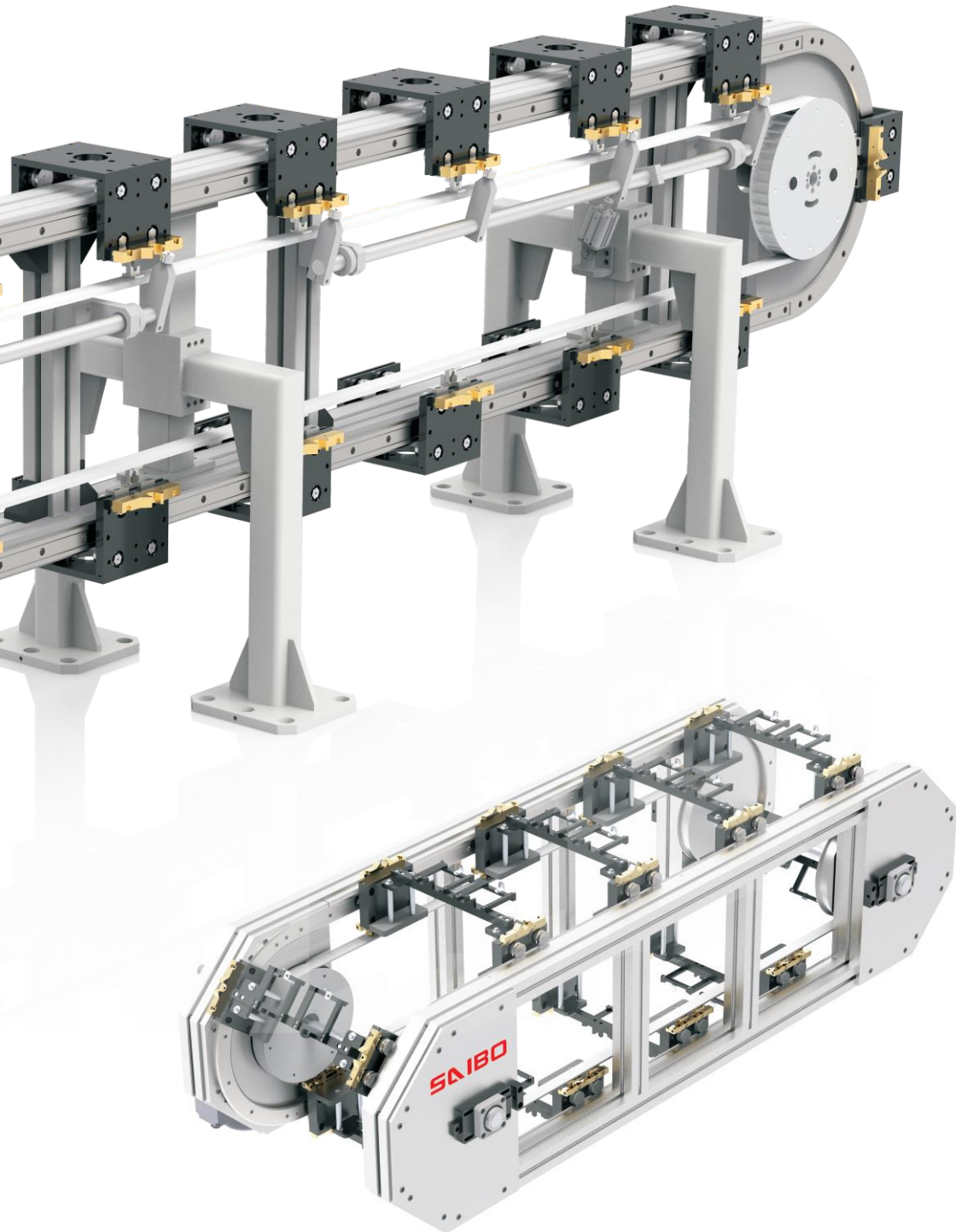

Vertical Conveyor with Two Parallel Curved Rail

This conveyor is configured with two circular guide rails, one rail uses fixed rollers and the other uses floating rollers. The distance between two rails can be set a larger distance, it is suitable for transmitting workpieces or tooling with a large length.

WUXI SAIBO INDUSTRY CO LTD

6-701 XIHU EAST ROAD, WUXI 214011, CHINA

Tel: +86-510-8203 9930

www.saibo-motion.com
info@saibo-motion.com



S02E-2023

